



# **BF7264B MIPI D-PHY analyzer**

**Feature:**

The BF7264B is an MIPI D-PHY analyzer and offers other protocol analyzer options like eMMC5, NAND flash, SD3, or SD4 as its predecessor, the BF6264B.

**Specifications:**

**1. BF7264B, 32Gb RAM, MIPI D-PHY probes**

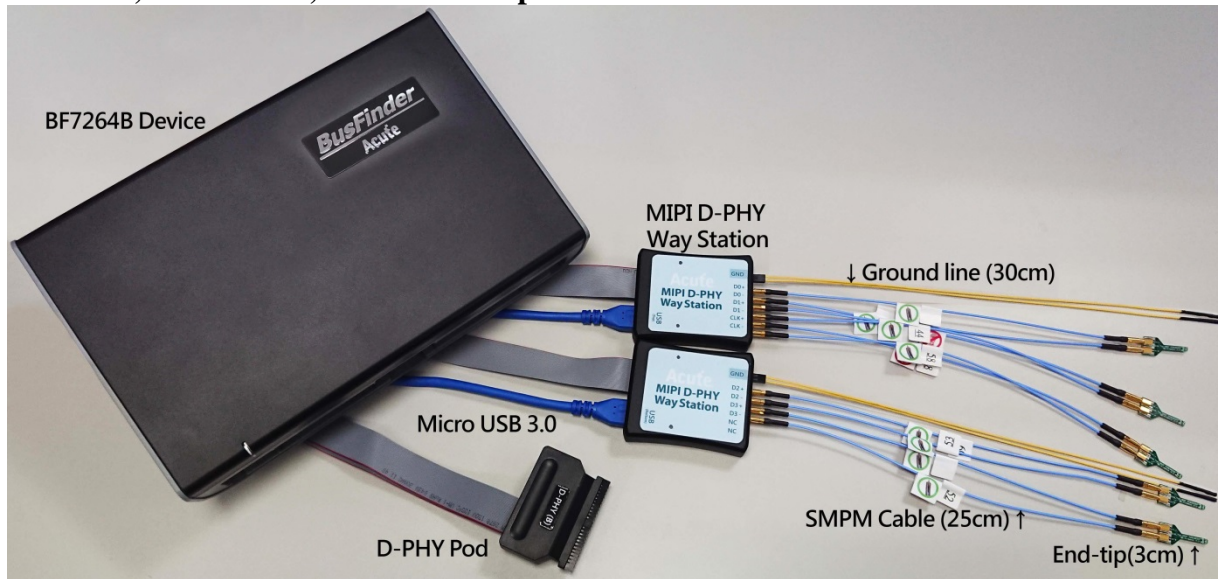

**2. supports D-PHY V1.2**

Up to 2.0Gbps per lane, 1 + 4 Lanes

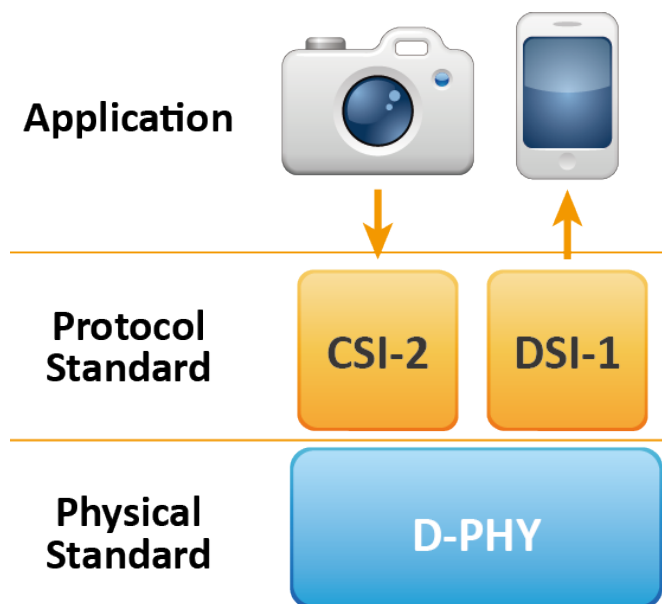

**3. CSI-2 1.3 or DSI 1.3 protocol packets displayed as below with the DSI DCS 1.3 commands**

Timestamp (time.ms.us.ds)	Mode	VC	Data Type	DCS (A)	WC	Data (B)	Transaction Type	ECC (C)	CRC (D)
10.637.049.8...	LP (LPDT)	0	Generic Long Write		2	B0 03	Host proces...	00 (OK)	F84D (OK)
10.637.060.1...	LP (LPDT)	0	DCS Short WRITE	53 (write control display)		24	Host proces...	08 (OK)	
10.637.066.5...	LP (LPDT)	0	DCS Short WRITE	35 (set tear on)		00	Host proces...	2F (OK)	
10.637.083.3...	LP (LPDT)	0	Generic Long Write		2	B0 04	Host proces...	00 (OK)	8CF2 (OK)
10.637.105.0...	LP (LPDT)	0	Generic Long Write		3	EB 00 83	Host proces...	1A (OK)	AF71 (OK)
10.637.124.2...	LP (LPDT)	0	Generic Long Write		2	FB 00	Host proces...	00 (OK)	6818 (OK)
10.637.179.2...	LP (LPDT)	0	Generic Long Write		20	C8 01 00 04 FB FC CD 00...	Host proces...	19 (OK)	B76A (OK)
10.637.196.0...	LP (LPDT)	0	Generic Long Write		2	D6 01	Host proces...	00 (OK)	EADA (OK)
10.637.208.8...	LP (LPDT)	0	Generic Long Write		2	B0 03	Host proces...	00 (OK)	F84D (OK)
10.637.219.1...	LP (LPDT)	0	DCS Short WRITE	11 (exit sleep mode)		00	Host proces...	36 (OK)	
10.837.205.4...	LP (LPDT)	0	DCS Short WRITE	29 (set display on)		00	Host proces...	1C (OK)	
10.870.540.9...	LP (LPDT)	0	DCS Short WRITE	51 (set display brightness)		FE	Host proces...	0D (OK)	
10.870.560.9...	LP (LPDT)	0	DCS READ, no par...	DA		00	Host proces...	1F (OK)	
10.870.562.6...	BTA								
10.870.571.3...	LP (LPDT)	0	DCS Short READ R...			E1 00	Peripheral ...	27 (OK)	
10.870.573.4...	BTA								
10.897.116.1...	HS	0	DCS Long Write/w...	2C (write memory_start)	2881	DC AC AA 9A 5A DC DE D2...	Host proces...	04 (OK)	
10.897.116.1...	HS	0	End of Transmiss...			0F 0F	Host proces...	01 (OK)	
10.897.134.6...	HS	0	DCS Long Write/w...	3C (write memory_continue)	2881	CA 1B CC EC 7A 5C 55 D2...	Host proces...	04 (OK)	
10.897.134.6...	HS	0	End of Transmiss...			0F 0F	Host proces...	01 (OK)	
10.897.153.2...	HS	0	DCS Long Write/w...	3C (write memory_continue)	2881	CA FD C2 CF F1 B0 3B 77...	Host proces...	04 (OK)	
10.897.153.2...	HS	0	End of Transmiss...			0F 0F	Host proces...	01 (OK)	
10.897.171.7...	HS	0	DCS Long Write/w...	3C (write memory_continue)	2881	3A 62 52 93 5E 8A 1B 77...	Host proces...	04 (OK)	
10.897.171.7...	HS	0	End of Transmiss...			0F 0F	Host proces...	01 (OK)	
10.897.190.2...	HS	0	DCS Long Write/w...	3C (write memory_continue)	2881	BA 15 C3 CF E5 B8 1E 6D...	Host proces...	04 (OK)	
10.897.190.2...	HS	0	End of Transmiss...			0F 0F	Host proces...	01 (OK)	

**4. Use 32Gb RAM as the buffer to stream all D-PHY data into the SSD HD in order to record all data flow from Low Power Mode to High Speed Mode**  
Recordable data without streaming into the SSD HD:

Resolutions	Recordable frames	Note
1K (FHD 1080x1920)	~500	
2K (WQHD 1440x2560)	~280	
4K (UHD 2160x3840)	~120	8 lanes or 4 lanes with DSC compression
8K (4320x8192)	Not available	Not available

- “Data Filter” filters unwanted video data to save memory**
- “Search” searches specific data**
- “ECC/CRC Packet” displays and counts ECC and CRC**
- Display DSI(CSI) image data including RGB, YCbCr, RAW format or compressed DSC packets, and count the Porch from raw data.**

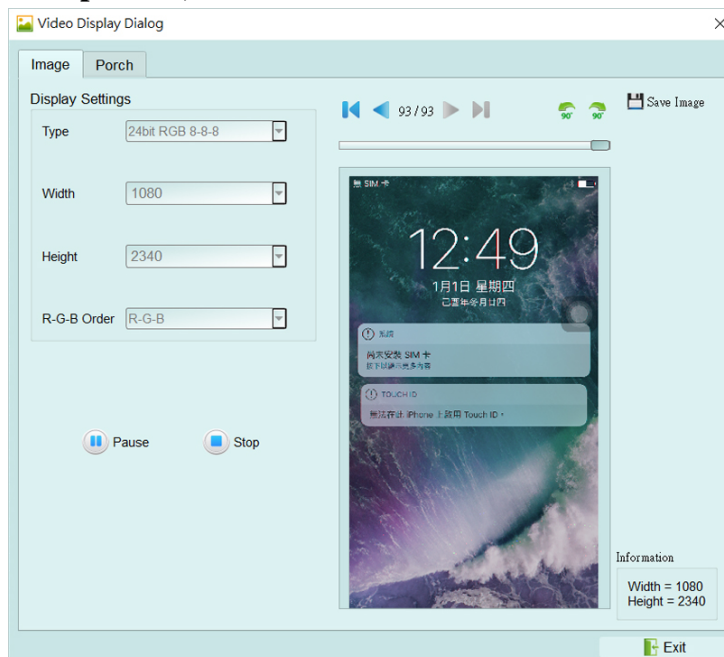

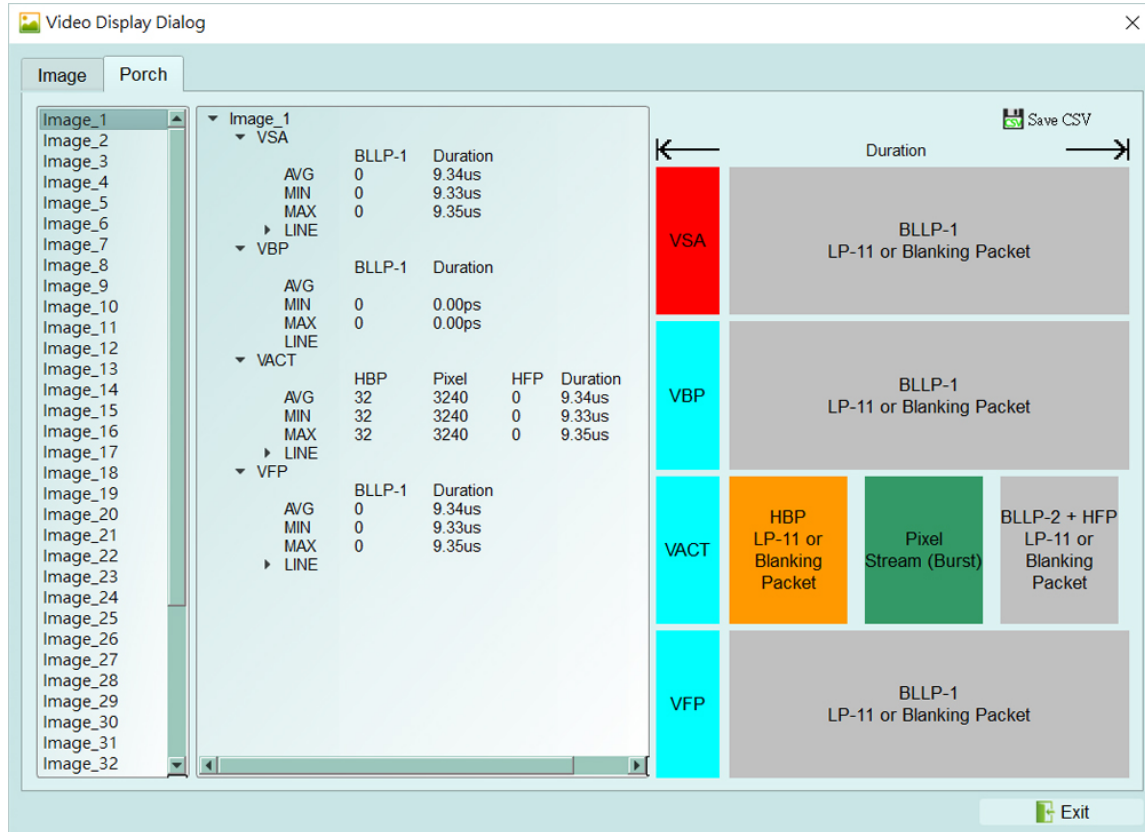

**9. D-PHY command statistics include numbers of packets, individual command, different data length, and errors**

Discription	Txns	Bytes	Statistics	Txns	Bytes
▶ Sampled Bus Error	2455		5E (set_CABC...	1	1
▶ DSI Error Report	0		55 (write_pow...	2	4
▼ DSI Bus			53 (write_cont...	1	1
VC 0	1044640	29739051	35 (set_tear_on)	1	1
VC 1	18	37	11 (exit_sleep...	1	1
VC 2	245	493	29 (set_displa...	1	1
VC 3	499	628	51 (set_displa...	1	1
BTA	14		DA	1	1
Data Type	1044899	29740212	2C (write_me...	407	22385
DCS Command	521835	28694276	3C (write_me...	521293	28670727
Packet Count	1044900		20 (exit_invert...	3	129
			78	2	86
			1E	2	86
			60	2	44
			80	1	43

**10. D-PHY command trigger**

- a. Trigger parameters include commands and 32 bytes data in order to cover all short packets and most of non-video long packets.

Short Packet: 4-bytes Header

Long Packet: 4-bytes Header + 28-bytes Data

- b. CRC/ECC error trigger
- c. The Trigger-Out port is to trigger a DSO to capture waveforms

## FAQ

### Q1. What MIPI DSI version is supported, any limitation for differential ports?

A: D-PHY V1.2, up to 2.0Gbps per lane, 1 + 4 lanes.

### Q2. Is C-PHY supported?

A: No. Not now or in the future.

### Q3. Is DSI-2 supported?

A: No, DSI-2 includes C-PHY signal which is not supported in this solution, the VDC-M image compression/decompression in DSI-2 is also not supported.

### Q4. Will signal quality be affected while measuring?

A: Yes, that is why the end-tips and the SMPM coaxial cables are used to minimize the affections of signal quality.

### Q5. Is Tx supported?

A: No.

### Q6. How to connect the probes with the DUT?

A : ① Weld the DUT: the welding line MUST be < 5mm.

On the DUT, you are highly recommended to weld a 100Ω resistor and connect it to the End tip with a 3cm line.

**Step 1: Connect the SMPM-SMPM cable to the End-tip first.**



**Step 2: Weld the End-tip to the DUT after Step 1.**

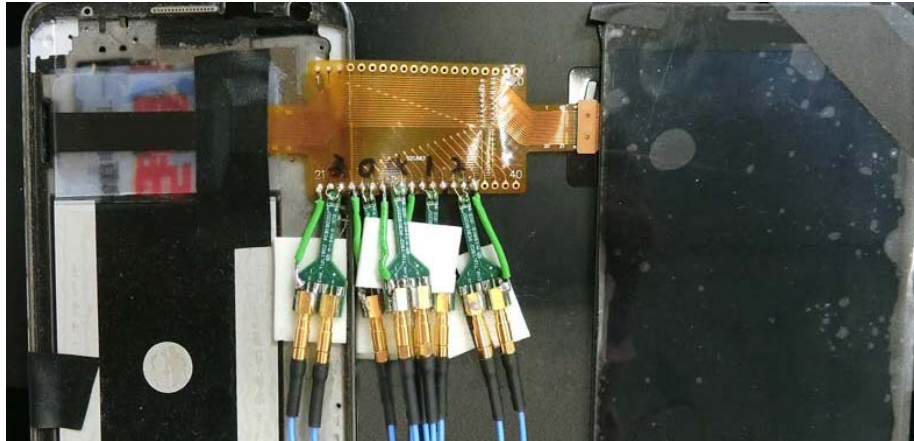

※ End-tip R1/R2 resistor is  $1k\Omega/0402$  which can be replaced if it breaks.

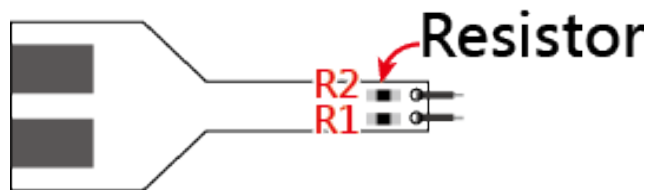

② 2.0mm pin header (PH): though easier to use, but will lead to lower signal quality due to stub effect.

Weld  $1k\Omega$  resistor on the DUT, then the pin socket; Weld the PH on the End-tip and short the End-tip's  $1k\Omega$  resistor to lower the stub effect.



Note: Use hot melt adhesive to reinforce the End-tip.

③ User-tip : User can design his own End-tip with  $1k\Omega$  resistor to connect the DUT, then use the  $50\Omega$  impedance PCB trace to plug the SMPM connector.

④ Breakout: User can design his own EV board with the SMPM connector to connect Acute MIPI D-PHY analyzer by breaking out the D-PHY host and device on the PCB board as the chart below. R1/R2/R3 must be as close as possible by using  $50\Omega$  impedance.

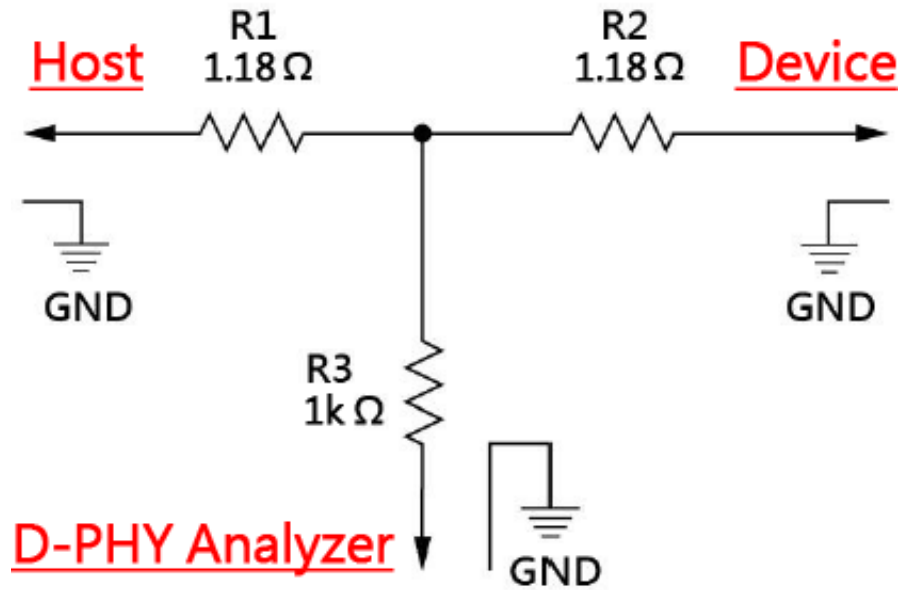

**Q7. Use multimeter to check the short circuit.**

After connections as below.

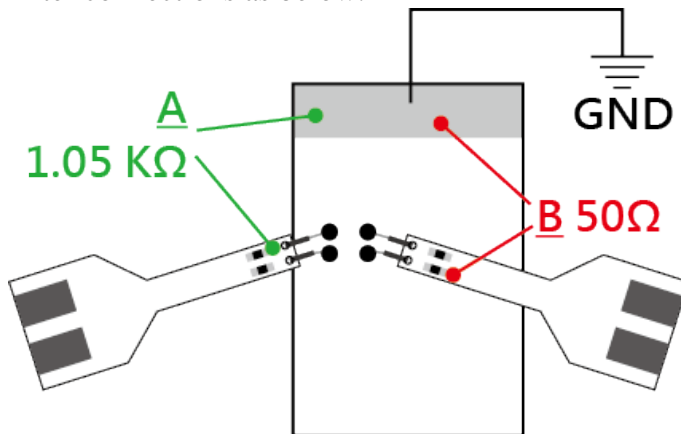

Check point **A**: End-tip resistor front to ground, **green line** ==> no sound from a multimeter.

Check point **B**: End-tip resistor back to ground, **red line** ==> sound from a multimeter, any short circuit?

A sound from a multimeter at point **B** is normal because it is low impedance of 50Ω at the resistor back. So, there is no short circuit if the resistor front of 1.05 KΩ without any sound.

**Q8. How to connect the ground?**

Two ways to connect the ground: End-tip or Way Station. It is better connect the End-tip ground to the DUT ground to have the better quality; but the user may use the Way Station ground for convenience but to have lower quality signal.

**Q9. Is DSI/CSI Data Type or Data trigger supported?**

A: Yes, Data Type, DCS Command and Data trigger are supported by BF7264.

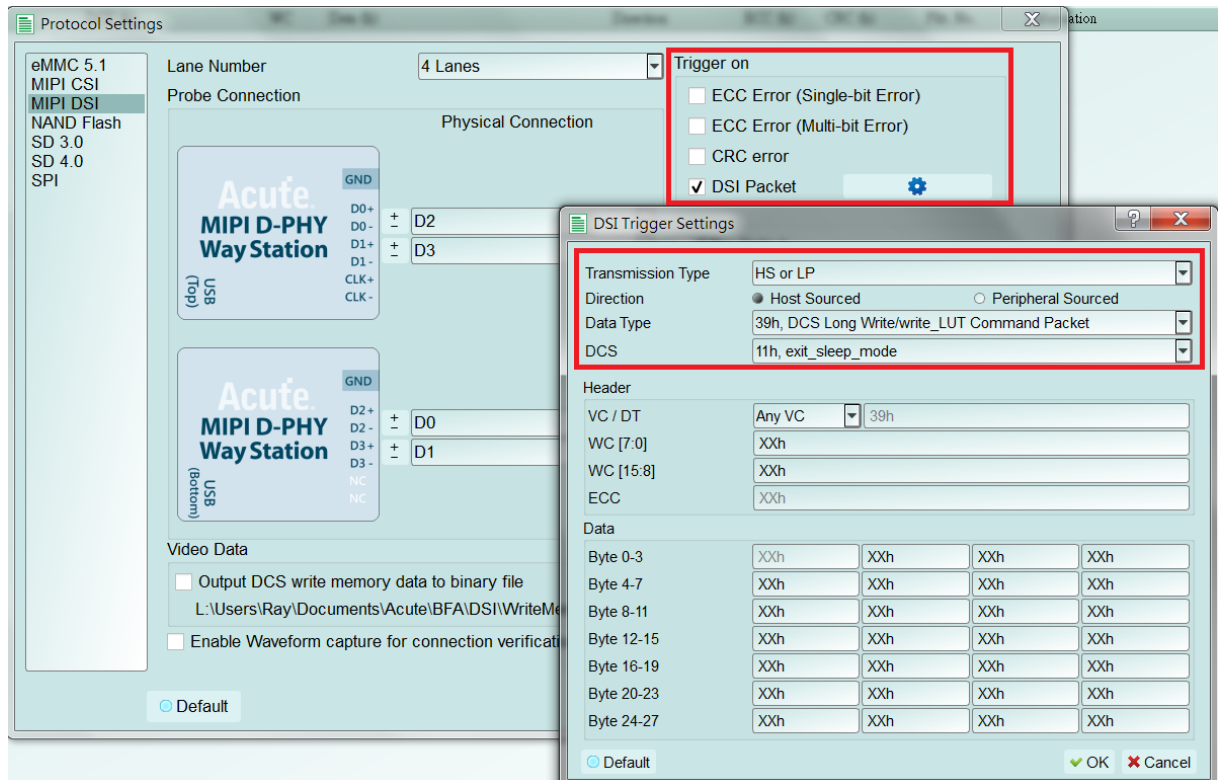

**Q10. Is that possible to setup a HS, LP or DCS command as a start condition and then capture data within specified time range?**

A: Yes, after setup the HS, LP or DCS in the trigger settings as start condition, move to Configuration and change the operation mode to Protocol Monitor mode, then you can specify the required capture time range.



